

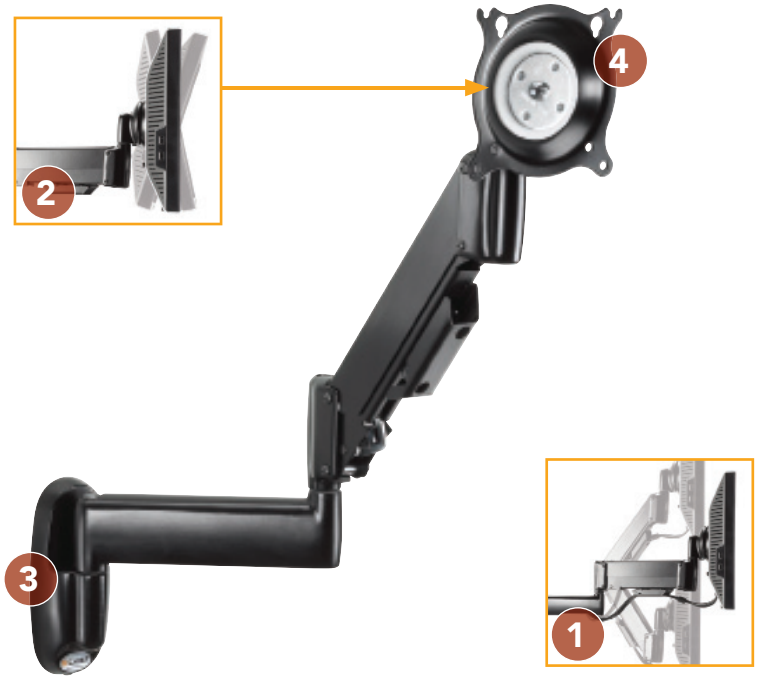

## FEATURES

- 1 FINGERTIP HEIGHT ADJUSTMENT**  
Adjust viewing height up to 13.25" (337 mm). Optimize height adjustment for any display with customizable tension.
- 2 CENTRIS® TECHNOLOGY PATENTED FEATURE**  
Provides smooth fingertip tilt in all directions using the screen's center of gravity. Screen angle stays set until you decide to readjust.
- 3 COMPATIBLE WITH OFFICE FURNITURE**  
Custom OFB office furniture interface brackets available for most office systems. (OFB brackets sold separately)
- 4 ADVANCED DISPLAY MOUNTING**  
Teardrop hole pattern makes mounting the screen quick and easy.



## SPECIFICATIONS

Depth from Wall	2.19" (56 mm)
Max. Extension	19.5" (495 mm)
Height Adjustment	13.25" (337 mm)
Tilt	±15°
Weight Capacity	5-25 lbs (2.3 - 11.4 kg)
Colors	Black, Silver

## WHAT YOU NEED TO KNOW

### OTHER PRODUCT OPTIONS



**KWV110**  
Height-Adjustable  
Single Arm Mount



**KWB110**  
Height-Adjustable  
Triple Arm Mount



**KWGSK110**  
Height-Adjustable Steel Stud Mount

## TECHNICAL DRAWINGS

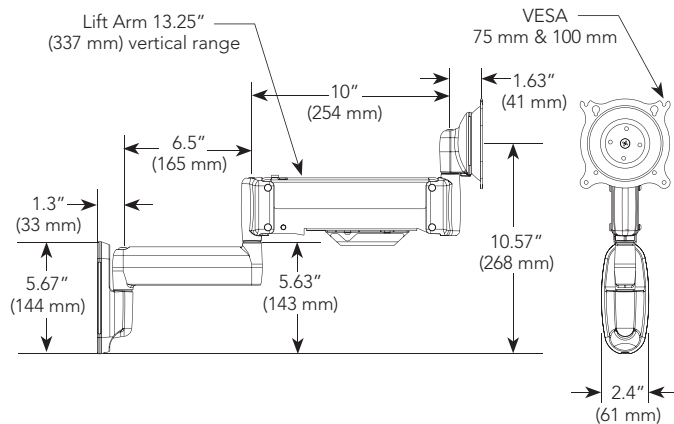

## RECOMMENDED ACCESSORIES



**KSA1003** ■ Extension Arm  
– Maximum of 3 arms  
– Weight capacity is reduced to 30 lbs (13.6 kg)



**KSA1021** ■ Keyboard Tray Accessory

For a complete list of monitor mount accessories see page 111.