



STEPS FOR ASSEMBLING MULTIPLE CONSOLE UNITS:

1. REMOVE ALL PACKAGING MATERIALS & PLACE UNITS ON FLOOR NEAR FINAL INSTALLATION AREA.
2. SLIDE ALL UNITS TOGETHER AND ADJUST LEVELERS (Note "A") AS REQUIRED TO BRING INTO "ROUGH" ALIGNMENT.
3. USING #10-32 BOLTS SUPPLIED LOOSELY FASTEN EACH UNITS WORKSURFACES TOGETHER AT (3) POINTS ALONG EACH SEAM BETWEEN ADJACENT SECTIONS (Note "B").
4. IF WEDGES ARE INCLUDED IN THE INSTALLATION, HANG THEM BETWEEN UNITS AS ILLUSTRATED (Note "C").
5. RECHECK LEVEL & TIGHTEN WORKSURFACE BOLTS BEGINNING AT CENTER OF CONSOLE LINEUP AND WORK OUTWARD; RECHECKING LEVEL AND THAT FRONT EDGES ARE ALIGNED AS YOU GO.
6. INSTALL HORIZONTAL WIREWAY PLUGS; QTY 2 ON EACH END (Note "D").

ALL ASSEMBLY HARDWARE SHIPPED IN CABINET OF UNIT #1
(LEFT MOST UNIT IN CONSOLE LINE UP).

NOTE: UNIT NUMBER CAN BE FOUND ON LABEL ABOVE CABINET DOOR ON LEFT SIDE OF EA. UNIT

ASSEMBLY TOOLS REQUIRED:

- 3 Ft. Level (or Longest Available)
- 7/16" Open End Wrenches (Worksurfaces)
- 5/8" Open End Wrench (for Levelers)
- Philips Screw Driver (Cover Panels)

TIPS: DO NOT TIGHTEN BOLTS UNTIL UNITS ARE LEVELED AND ALL BOLTS ARE IN PLACE.

BOLTS ARE INSERTED FROM INSIDE CABINETS. REAR PANELS REMOVABLE FOR EASIER ASSY.

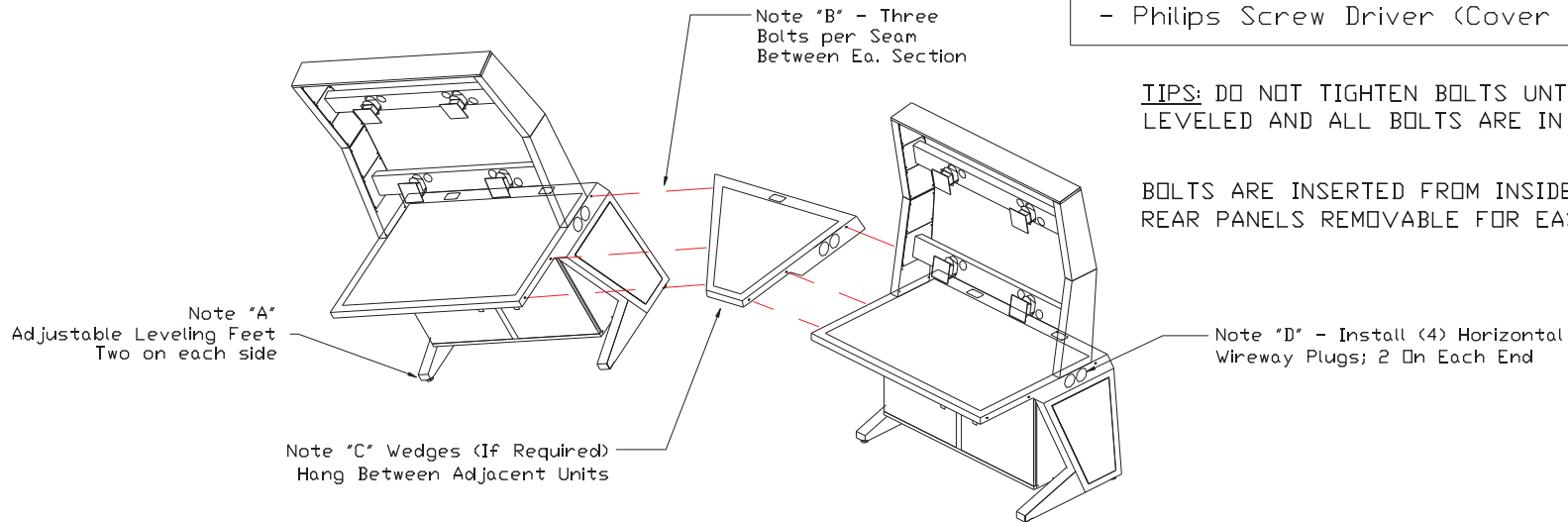

**IF YOU EXPERIENCE DIFFICULTY
DURING ASSEMBLY CONTACT
IMAGEVISION, INC.
888-664-6762**

IMAGEVISION, INC. Modular Consoles PO Box F La Grange, TX 78945 (888) 664-6762 (979) 247-4068 Fax: (979) 247-4062 http://www.ImageVisionInc.com	DWG. SCALE: 1 in = 48 in	TITLE: AGILEVIEW, SECUREVIEW & MEDIVIEW BASE UNIT & WEDGE ASSEMBLY INSTRUCTIONS
	DATE: 11/3/05 BY: DAR	
	PAGE NO. 1 OF 3	DRAWING NUMBER: GR810000

MONITOR RISER REMOVAL & ASSEMBLY INSTRUCTIONS:

(Required when moving tiered console units through 30 in. doorways)

STEPS

1. Remove all packaging material & place a piece of protective cardboard over the worksurface laminate to avoid damage during monitor riser removal & handling.
2. To provide easy access to the underside fasteners, remove front door(s) by opening door and releasing spring hinge pin.
3. Remove lower close up panels on inside of lower monitor riser frame. There is one closeup panel on each side. Panels are removed using a phillips head screwdriver to remove the four screws on each panel. Only the lowest panel on each side needs to be removed.
4. This step requires two personnel to complete safely - one working above the worksurface and one working inside the lower cabinet to access fastening nuts on the lower side of the worksurface. Carefully loosen nuts and then remove bolts from upper side behind lower close up panels removed earlier. Using two people, move the riser assembly off the worksurface and place on a protected, solid level surface.
5. With a person on each end of console unit, pick up base unit, rotate it with back side facing down, and carry base through doorway. Then carry monitor riser through door separately.
6. Reverse the steps above to reassemble units in final install location.

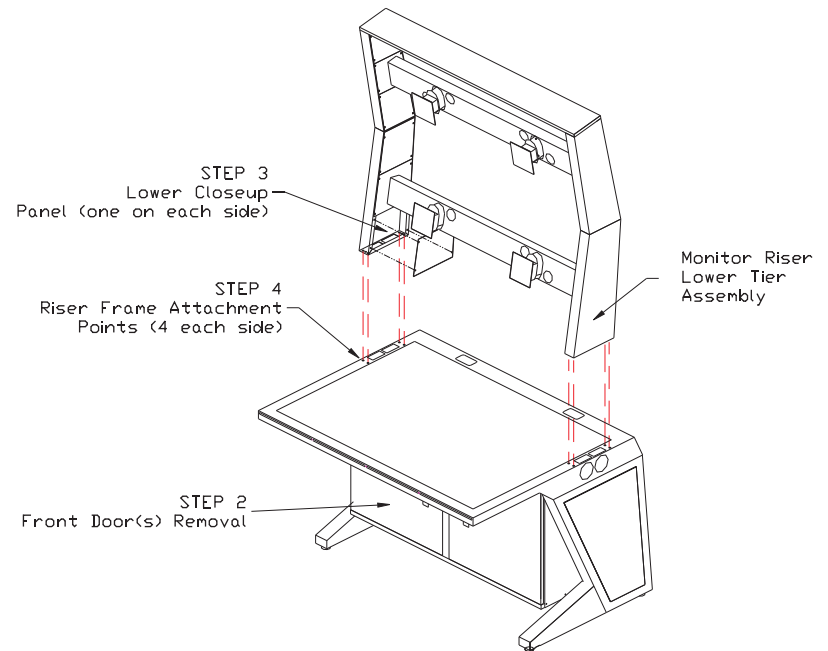

**IF YOU EXPERIENCE DIFFICULTY
DURING ASSEMBLY CONTACT
IMAGEVISION, INC.
888-664-6762**

IMAGEVISION, INC. Modular Consoles PO Box F La Grange, TX 78945 (888) 664-6762 (979) 247-4068 Fax: (979) 247-4062 http://www.ImageVisionInc.com	DWG. SCALE: 1 in - 48 in	TITLE: AGILEVIEW, SECUREVIEW & MEDIVIEW MONITOR RISER REMOVAL & ASSEMBLY INSTRUCTIONS
	DATE: 11/3/05 BY: DAR	
	PAGE NO. 2 OF 3	DRAWING NUMBER: GR810000 REVISION: F1



STEPS FOR ASSEMBLING CORNER TABLE/ CONSOLE UNITS:

1. REMOVE ALL PACKAGING MATERIALS & PLACE UNITS ON FLOOR NEAR FINAL INSTALLATION AREA.
2. SLIDE UNITS ADJACENT TO CORNER TABLE INTO POSITION AS REQUIRED AND ADJUST LEVELERS (NOTE A) TO BRING INTO ROUGH ALIGNMENT.
3. PRIOR TO POSITIONING CORNER TABLE BETWEEN ADJACENT CONSOLES, THE CORNER TABLE LEG (NOTE "B") MUST BE INSTALLED. PLACE CORNER TABLE UPSIDE DOWN ON CARDBOARD PROTECTED SURFACE FOR LEG INSTALLATION. LEG IS CONNECTED TO WORK SURFACE WITH (4) 5/16"-18 x 3/4"LG SCREWS WITH FLAT WASHERS, LOCK WASHERS AND NUTS. IF CORNER TABLE IS ADJACENT TO A WORKSURFACE SPANNER SECTION, AN ADDITIONAL REAR LEG WILL NEED TO BE INSTALLED NEXT TO THE SPANNER SECTION.
4. AFTER THE LEG/S HAS BEEN IN INSTALLED, POSITION CORNER TABLE UPRIGHT WITH ONE PERSON POSITIONED AT THE REAR CORNER LEG AND A SECOND PERSON IN FRONT, WHO WILL HAVE TO REACH INSIDE ADJACENT CABINET TO LOOSELY FASTEN THE FIRST OF (6) .25"-20 x 3/4"LG MACHINE BOLTS (NOTE "C") INTO NUTCERTS IN CORNER TABLE WORK SURFACE. AFTER THEY ARE ALL LOOSELY FASTENED, GRADUALLY TIGHTEN EACH WORKING BACK AND FORTH BETWEEN THE TWO SIDES OF THE CORNER TABLE MAKING SURE THAT THE (3) WORK SURFACES STAY FLUSH AND LEVEL.
5. RECHECK LEVEL & TIGHTEN WORKSURFACE BOLTS BEGINNING AT CENTER OF CONSOLE LINEUP AND WORK OUTWARD; RECHECKING LEVEL AND THAT FRONT EDGES ARE ALIGNED AS YOU GO.
6. INSTALL HORIZONTAL WIREWAY PLUGS; QTY 2 ON EACH END (NOTE "D").

ALL ASSEMBLY HARDWARE SHIPPED IN CABINET OF UNIT #1
(LEFT MOST UNIT IN CONSOLE LINE UP).

NOTE: UNIT NUMBER CAN BE FOUND ON LABEL ABOVE CABINET DOOR ON LEFT SIDE OF EA. UNIT

ASSEMBLY TOOLS REQUIRED:

- 3 Ft. Level (or Longest Available)
- 7/16" Open End Wrenches (Worksurfaces)
- 5/8" Open End Wrench (for Levelers)
- Philips Screw Driver (Cover Panels)

TIPS: DO NOT TIGHTEN BOLTS UNTIL UNITS ARE LEVELED AND ALL BOLTS ARE IN PLACE.

BOLTS ARE INSERTED FROM INSIDE CABINETS. REAR PANELS REMOVABLE FOR EASIER ASSY.

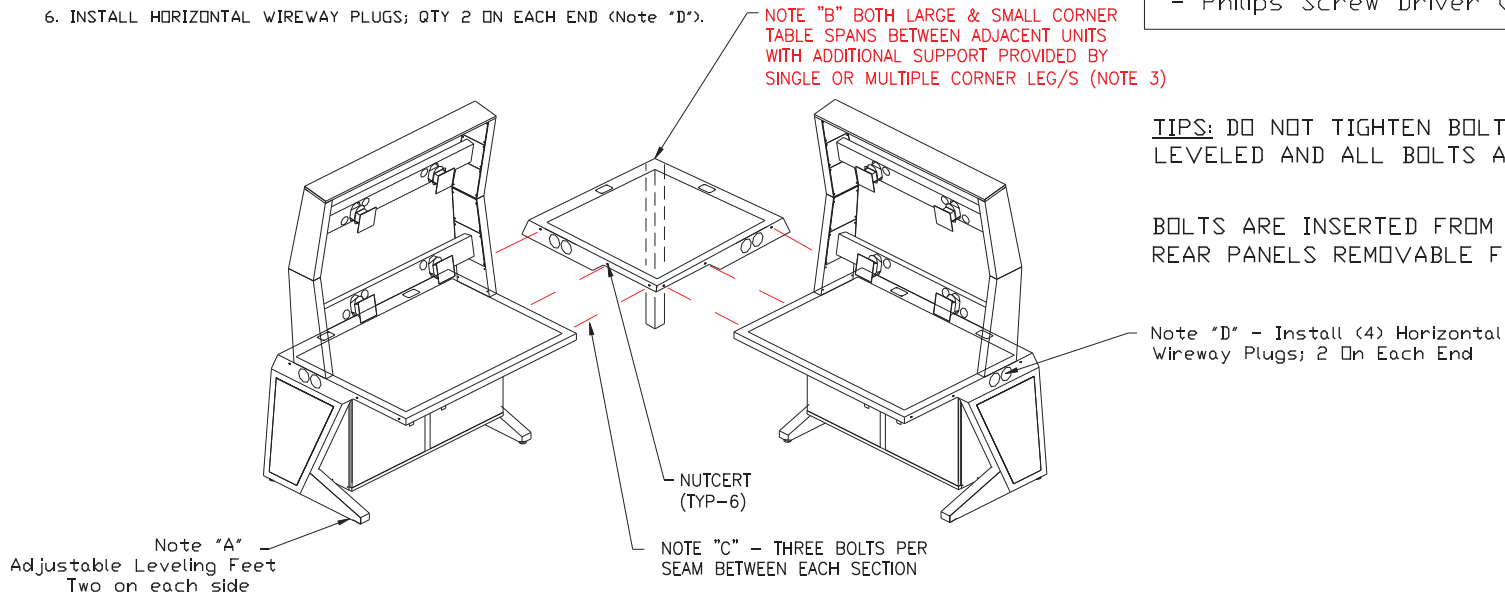

IF YOU EXPERIENCE DIFFICULTY DURING ASSEMBLY CONTACT IMAGEVISION, INC. 888-664-6762

IMAGEVISION, INC. Modular Consoles PO Box F La Grange, TX 78945 (888) 664-6762 (979) 247-4068 Fax: (979) 247-4062 http://www.ImageVisionInc.com	DWG. SCALE:	1 in - 48 in	TITLE:	AGILEVIEW, SECUREVIEW & MEDIVIEW BASE UNIT & CORNER TABLE ASSEMBLY INSTRUCTIONS	
	DATE:	11/3/05	BY:	BT	
	PAGE NO.	3 OF 3	DRAWING NUMBER:	GR810000	REVISION: