

Assembly Tools, Cabinet Keys and Shipping Documents

Tool Lists:

- 3 ft. Level; or longer if available.
- 5/16" Open End Wrench; for joining console worksurfaces.
- 3/8" Open End Wrench; for adjusting & locking leveling feet.
- Phillips Head Screwdriver; for removing cover panels if required.

Assembly Hardware Location:

Hardware for installing your console units is shipped inside the cabinet of Module #1; left end unit in the console lineup. All surge protected power strips are also shipped in Module #1.

Console Cabinet Keys:

Keys for console cabinet cylinder locks are shipped inside a 3X5in. manila envelope and are taped to the work surface of each console below protective cardboard.

Packing List, Drawings & Instructions:

Packing List is in an enclosure packet taped to the outside of the shrink wrap on top of worksurface of Unit #1 (left end).

Drawings & Assy. Instructions in FedEx envelop taped on Module #1

Console Unit#/Module# ID Tag is located under worksurface here

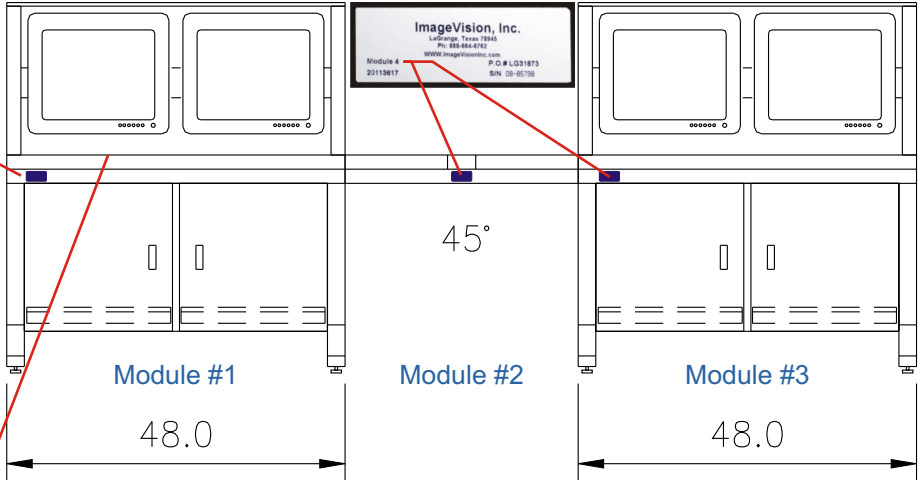

Each console unit is individually shrink wrapped, edge protected and strapped to custom pallets for shipment. Depending on shipping distance & number of transfers, console units may be crated

Unit#/Module# ID Tag is located above left side door Tag can be read without removing console shrink wrap

Track Your Shipment: [LEARN MORE...](#)

Contact Us for Assistance
Phone: 888-664-6762
Email: sales@imagevisioninc.com

AgileVIEW Assembly & Installation Instructions:
Assembly Tools, Keys and Shipping Documents
AG1400-01-revB (replaces GR810000) Page 1 of 8

Console Base Unit, Wedge Angle, and Spanner Assembly

Installation Steps:

1. Remove all packaging materials and move units to area for final install. Insure Module #'s (see pg1) are positioned in proper sequence left to right. Be careful not to discard any shipping documents or keys.
2. Starting in middle of console unit lineup, slide all units together and adjust leveling feet as needed to bring the consoles into rough adjustment for level and alignment.
3. Using 5/16" #10-32 x 3/4" long hex bolts, flat & lock washers, & nuts supplied, loosely fasten ALL units together in 3 places (red dotted lines on right) along each seam between adjacent units or wedges.
4. If wedges are used in your installation, they will hang between two adjacent console base units as shown.
5. Starting in middle of the console lineup, re-level each console unit as needed both front-to-back and side-to-side with a 3 foot level. Tighten bolts between units starting in the middle of the lineup and work outwards towards each end; aligning front edges.
6. Install horizontal wireway end plugs; two 3 inch diameter plugs are supplied for each end. Install carefully as they're not easily removed.

To move units (Monitor Tiers uninstalled) through 30 in. door, you'll need 2 people to remove Tiers; pg4. Rotate base units 90 degrees with front of worksurface pointing upward, then carry unit through door.

Quick Tips:

Do not leave units unattached; can cause alignment problems. Do not tighten bolts until ALL UNITS are in place and loosely bolted together. This insures bolt holes will align easily.

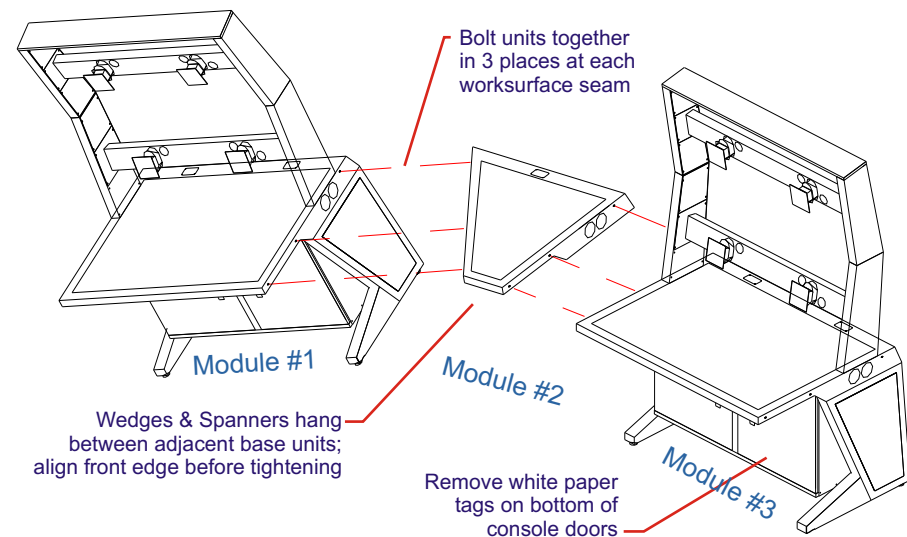

To insure stability of the console units and enhance your consoles overall appearance, bolt all units together!

Contact Us for Assistance

Phone: 888-664-6762

Email: sales@imagevisioninc.com

AgileVIEW Assembly & Installation Instructions:

Base Units, Wedge and Spanner Assembly
AG1400-01-revB (replaces GR810000) Page 2 of 8

CAUTION: Module#'s must be in correct order on both sides of corner tables for modesty panel spring pin holes to align properly.

www.imagevisioninc.com

Installing 90 Degree Corner Tables; Either Small Square or Large Beveled Front

Installation Steps:

1. Install leg per Installation Tip on right; (Hdwr. is under Top). Leg is mounted to work surface with (4) 5/16"-18 x 3/4" long screws with flat washers lock washers and nuts. If Table is adjacent to a Spanner section an additional leg will need to be installed next to the Spanner.
2. Slide units adjacent to corner table into position **noting Module Numbers on both sides are in proper sequence**. Adjust levelers to insure level both front-to-back and side-to-side using a 3 foot level (minimum). **Drawings & Assembly details in FedEx pouch taped to Module#1**
3. Position Corner Table upright with one person at the rear corner leg with a second person in front who will need to reach inside adjacent cabinet to loosely fasten the first of (6) 1/4"-20 x 3/4" long machine bolts into nutcerts in corner table work surface. After all six are loosely fastened, gradually tighten each working back and forth between the two sides insuring tops & fronts are flush & level.
4. Starting in middle of the console lineup, level as needed both front-to-back and side-to-side with a 3 foot level. Tighten bolts between units starting in the middle of the lineup Work outwards towards each end; aligning front edges as you go.
5. Install Horizontal Wireway End Plugs; four 3 inch diameter plugs.
6. Install the two Modesty Panels per note on right.

Quick Tips:

Turn Corner Table Work Surface upside down onto cardboard or pad to attach rear leg to back corner of table. Rear Leg mounting hardware is in envelope taped to bottom side of corner table top. Cabinet Rear Panels are removable for easier assembly.

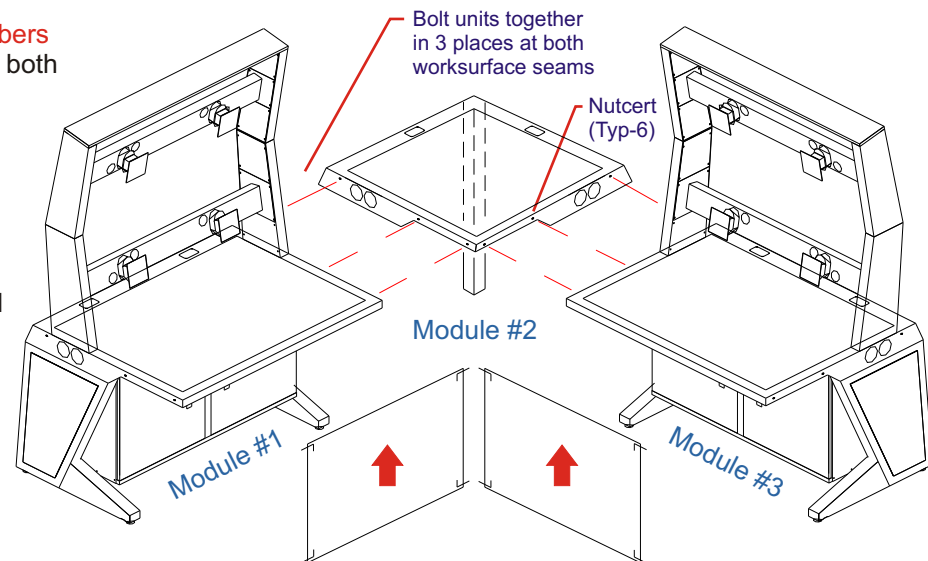

Final Step: Add Modesty Panels using spring pins on panel corners; pins pop into holes in adjacent units & corner leg **ONLY IF Modules are in proper sequence from left to right!**

Contact Us for Assistance

Phone: 888-664-6762

Email: sales@imagevisioninc.com

AgileVIEW Assembly & Installation Instructions:

90 Degree Corner Table Units; Large or Small Assembly
AG1400-01-revB (replaces GR810000) Page 3 of 8

Remove and Install Monitor Tiers from Base to Move Through 30in. Wide Door

Installation Steps:

1. Remove all packaging material and place a piece of protective cardboard on work surface laminate to avoid damage during Monitor Tier removal or installation.
2. To provide easy access to underside fasteners, remove Front Doors by opening doors and releasing spring hinge pins.
3. Remove Lower Close Up Panels on inside of lower Monitor Tier Frame. Panels are removed using a phillips screw driver. Only the bottom or lowest panel will typically need to be removed.
4. This step requires two people to complete the removal or assembly safely. One person will work above the work surface, while the other works from inside cabinet to access fastening nuts on bottom side of work surface. To remove Tiers, loosen nuts from bottom side, then remove bolt from top. Using two people, move Monitor Tier/s to a flat, clean surface.
5. With a person on each end of console base, pick it up and rotate it 90 degrees with front edge of work surface pointing straight up, and carry through doorway. Carry Monitor Tiers in through door separately.
6. Reverse steps above to install or reinstall Tiers to Base in final install location.

To move units with Monitor Tiers installed through a 30in. door, you will need to remove Tiers, Rotate base units 90 degrees with front of work surface pointing upward, then carry unit through door.

Quick Tips:

Use two people to remove or install Monitor Tiers.
Remove Front Doors using internal spring pins for easy access to bottoms of mounting bolt nut, lock & flat washer hardware.

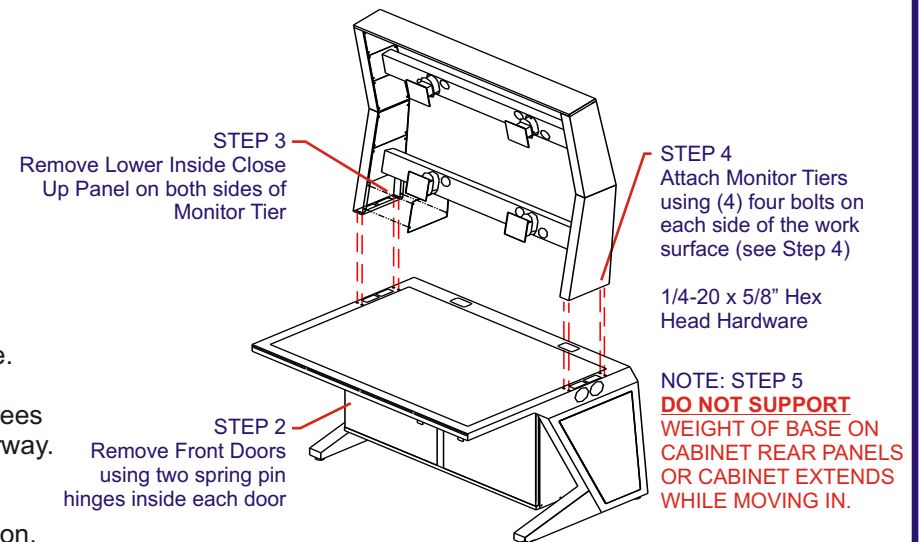

To insure stability of the console units and enhance your consoles overall appearance, bolt all units together!

Contact Us for Assistance

Phone: 888-664-6762

Email: sales@imagevisioninc.com

AgileVIEW Assembly & Installation Instructions:

Removing or Installing Monitor Tiers on Base Units Assembly
AG1400-01-revB (replaces GR810000) Page 4 of 8

Monitor Cables for All Screen Positions Are Color Coded on Both Ends

Installation Steps:

1. Typically, there is no assembly required! Console units normally ship with the Monitor Tiers installed. However, in some cases, due to special shipping requirements, Tiers ship unattached.

Quick Tips:

Video Cable and A/C Power Extension Cable for each monitor are color coded at both ends to identify their screen position for easy computer or equipment connections in cabinets below.

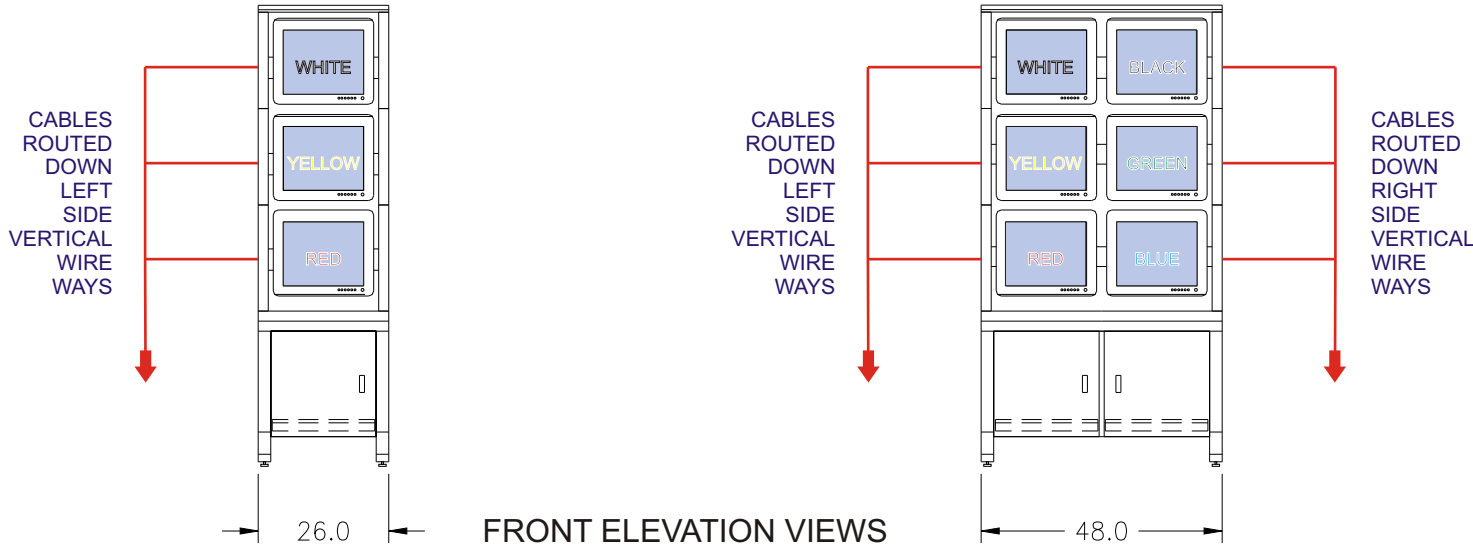

As standard, VGA Video Cables and Monitor A/C Power Extension Cables are color coded at both ends for each operator console screen position.

All cables are normally preinstalled at the factory unless instructed otherwise by customer or due to special shipping requirements.

Contact Us for Assistance

Phone: 888-664-6762
Email: sales@imagevisioninc.com

AgileVIEW Assembly & Installation Instructions:

Monitor Cables - Screen Position Color Codes
AG1400-01-revB (replaces GR810000) Page 5 of 8

Large Screen Display Mounting Instructions

Installation Steps:

1. See Assy Steps on Side View Drawing on right side of page.

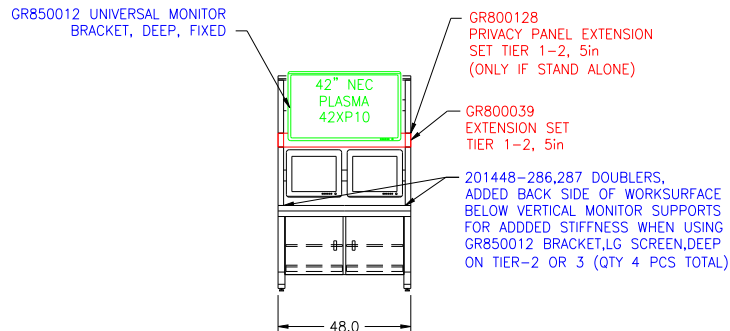
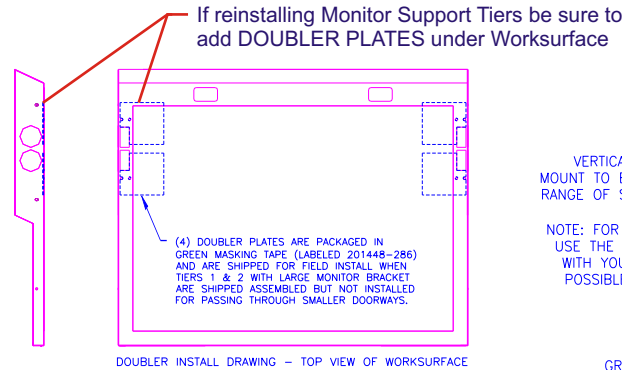

Quick Tips:

- Mount Vertical Screen Hangers to back of large screen first. Remember to tighten set screw at bottom of Vertical Hangers.

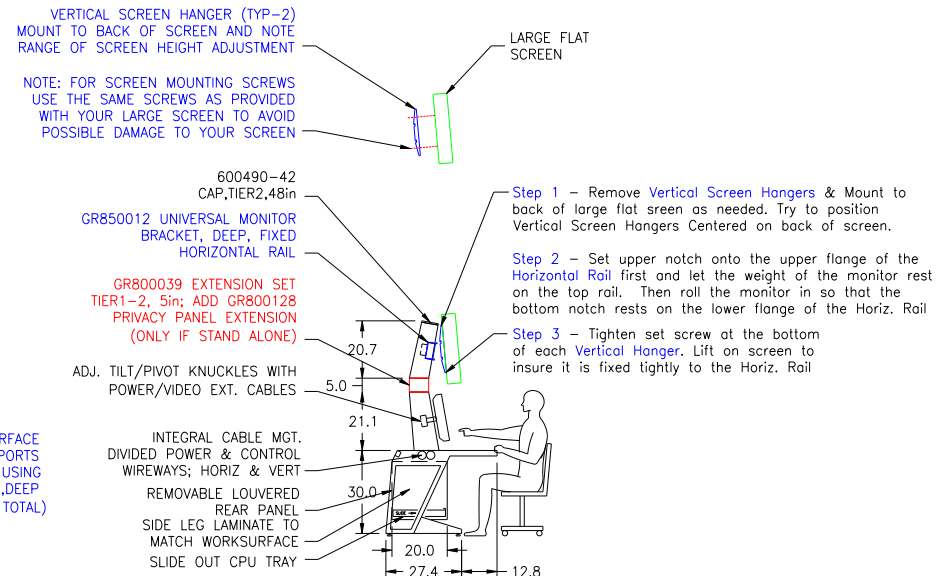

To move units with Monitor Tiers installed through a 30in. door, you will need to remove Tiers; pg4 Rotate base units 90 degrees with front of worksurface pointing upward, then carry unit through door.

To insure stability of the console units and enhance your consoles overall appearance, bolt all units together!

Doubler Plate Photos:

[LEARN MORE...](#)

Contact Us for Assistance

Phone: 888-664-6762
Email: sales@imagevisioninc.com

AgileVIEW Assembly & Installation Instructions:

Large Screen Display Mounting Instructions
AG1400-01-revB (replaces GR810000) Page 6 of 8

Assembly Instructions for Monitor Tier and Wedge Privacy Panels



Each console unit is equipped with Leveling Feet that work the same way as a washing machine
Proper leveling of all units & bolting all seams aids hole alignment when installing the Privacy Panels

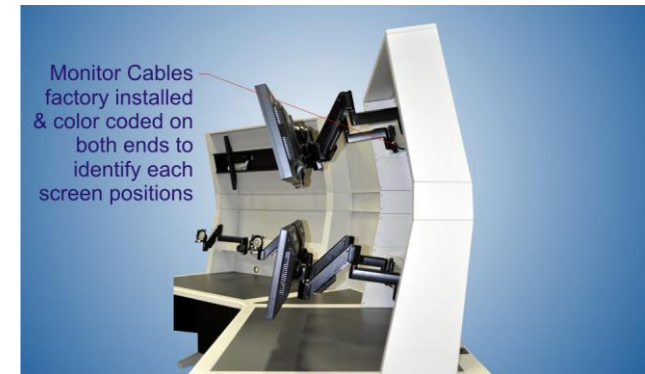

Install Privacy Panels behind each monitor tier first, then add Wedge Privacy Panels last as they overlap the tiers

Contact Us for Assistance

Phone: 888-664-6762

Email: sales@imagevisioninc.com

IV Part Number - Various:

Privacy Panels are easy to retrofit/field install
AG1400-01-revB (replaces GR810000) Page 7 of 8

Additional Links and Options for Download

Click Links Below to Learn More:

When planning for the arrival and installation of your operator console furniture, you will want quick access to some information that can help. Here they are:

- [VIEW Track Your Shipment](#)
- [VIEW Receiving & Handling Instructions](#)
- [VIEW Conduit and Cable Entry Options](#) - Field Install
- [VIEW Conduit and Cable Entry Options](#) - Factory Install
- [VIEW Mounting your LCD screens](#) to monitor support tiers
- [VIEW Top Shelf Spanner](#) - Field Installation Kit for Additional Storage
- [VIEW Ergonomic 7X24 Hour Rated Chair Options from Pinnacle](#)

Options to Expand or Update Your Console:

Our modular console designs allow for easy expansion and future additions to be made to your control room furniture and operator console units.

- [VIEW Privacy Panels](#) behind monitor tiers
- [VIEW Cabinet Extensions](#) for desk console units to accommodate deeper equipment in cabinets; 3, 6 & 12 inch Rear Extensions are available
- [VIEW Vertical Screen Repositioning](#); 2-Tiers
- [VIEW Dual Extension Monitor Arms](#); All Tiers
For additional control of LCD Screen Positions
- [VIEW AgileVIEW Options Photo Album](#)
See latest examples of our ever expanding list of standard options available for your console furniture

NEED ADDITIONAL HELP?
Call 888-664-6762
or email us at consoles@imagevisioninc.com

Contact Us for Assistance

Phone: 888-664-6762
Email: sales@imagevisioninc.com

AgileVIEW Assembly & Installation Instructions:

Additional Links and Options for Download
AG1400-01-revB (replaces GR810000) Page 8 of 8